

POWER AMPLIFIER LINEARIZATION USING DIGITAL PREDISTORTION

Hamid Ali¹, Manoj Gupta²
aman.155002@gmail.com¹, professormanojgupta@gmail.com²
Shobhit University Meerut

Abstract: For wideband or high power applications, the power amplifier exhibits memory effects, for which memory less predistorters can achieve only limited linearization performance. The memory polynomial predistorter can correct both the nonlinear distortions and the linear frequency response that may exist in the power amplifier. It is a robust predistorter, which has demonstrated good performance on several nonlinear system models. The predistorter models considered in this paper include both even- and odd order nonlinear terms. Here, the benefits to include even-order nonlinear terms in both the baseband power amplifier and predistorter models are described.

Introduction:

Power amplifiers are indispensable components in a communication system and are inherently nonlinear. The nonlinearity generates spectral regrowth, which leads to adjacent channel interference and violations of the out-of-band emission requirements mandated by regulatory bodies. It also causes in-band distortion, which degrades the bit error rate (BER) performance. To reduce the nonlinearity, the power amplifier can be backed off to operate within the linear portion of its operating curve. However, newer transmission formats, such as wideband code division multiple access (WCDMA) and orthogonal frequency division multiplexing (OFDM), have high peak to average power ratios, i.e., large fluctuations in their

signal envelopes. This means that the power amplifier needs to be backed off far from its saturation point, which results in very low

efficiencies, typically less than 10% ; i.e., more than 90% of the dc power is lost and turns into heat.

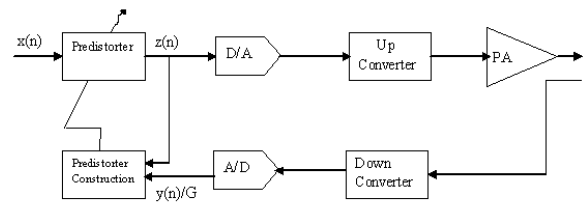

Fig 1: Digital predistortion block diagram

Digital predistortion implementations in the current literature mostly focus on the power amplifier that has a memoryless nonlinearity; i.e., the current output depends only on the current input through a nonlinear mechanism. This instantaneous nonlinearity is usually characterized by the AM/AM and AM/PM responses of the power amplifier, where the output signal amplitude and phase deviation of the power amplifier output are given as functions of the amplitude of its current input. There has been intensive research on predistortion techniques for memoryless power amplifiers during the past decade. As the signal bandwidth gets wider, such as in WCDMA, power amplifiers begin to exhibit memory effects.

In other words, the power amplifier becomes a nonlinear system with memory. For such a power amplifier, memoryless predistortion can achieve only very limited linearization performance. Therefore, digital predistorters also need to have memory structures. This paper investigates robust predistorter models that are capable of linearizing power amplifiers with memory effects. It also investigates system implementation issues related to these wideband digital predistortion systems.

Gain and Output Power:

In mobile communications each system has its specifications which must be fulfilled. Obtaining output powers high enough for various applications is a very important task achieved by Power Amplifiers. In general the information signal is first modulated and up converted, and then sent to a PA. This input is multiplied with a gain factor and the desired output power is obtained. Gain is handled in dB and power in dBm throughout this thesis. Fig.2 and 3 show example PA output and gain versus input power characteristics of a linear PA respectively. PA output versus input power characteristics shown in fig. 2 is also called AM/AM characteristics of the PA As it can be seen from the figures the gain is constant for low input powers and it reduces with approaching its saturation region. Saturation region is easily visible from the output power curve where the output power stays constant with further increase of the input power. In

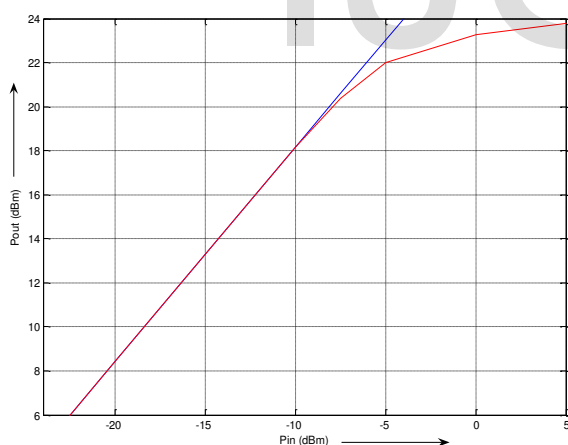

the

Fig 2. Output power characteristics of power amplifier

fig. 3 1 dB compression point is also shown, which refers to the output power level at which the amplifier's transfer characteristics deviates from the ideal one by 1 dB [3]. This is a widely used measure of amplifier linearity revealing roughly which linear

output power value is achievable with the device under test (DUT).

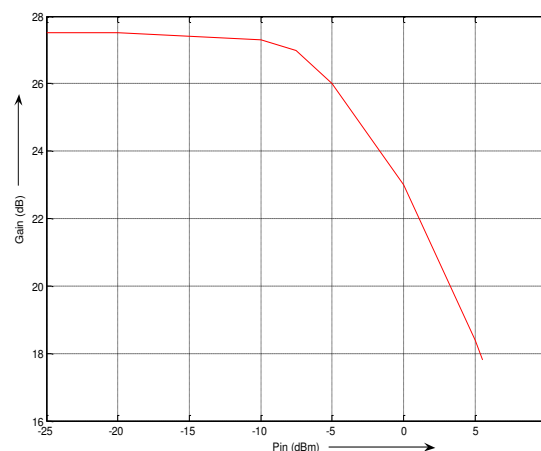

Fig 3: Gain of the Power amplifier

Review of Power Amplifier

Linearization Methods:

Power amplifier linearization is currently one of the most promising techniques for linearity and efficiency improvement in mobile communication systems. There are numerous techniques which have different levels of complexity, various advantages and limitations [2]. Different linearization methods may fit to different communication systems. For example more sophisticated high performance systems may be used for base station PAs whereas the systems usable in handsets should have low complexity, low cost and high efficiency. Although in general the main reason to implement these systems is to linearize the PA, they improve also the efficiency because a linearized PA can be driven closer to compression (operation with low back-off). In the following sections several PA linearization methods are explained which can be classified mainly as feedback, feedforward and predistortion systems.

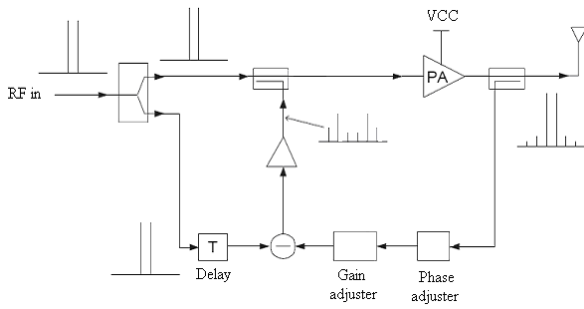

Figure 4: RF feedback linearization topology

Polar loop:

In polar loop linearization AM/AM and AM/PM nonlinearities are corrected by two individual loops as shown in fig. 5. The feedback is done in general at IF but RF Implementation is also possible. In [2] a polar loop concept is presented having low complexity and being applicable to EDGE. In the previous chapter PLTx has been introduced which is an efficiency enhancement method, rather than linearity improvement method but it has also a good degree of linearity.

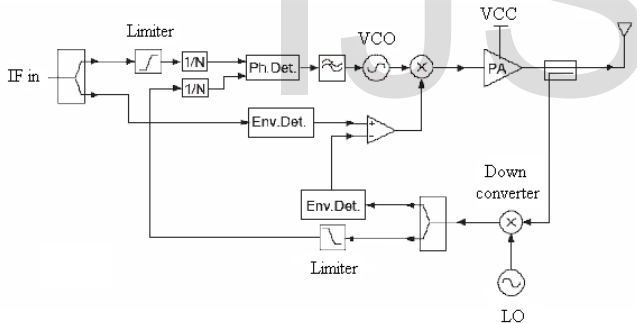

Figure 5: Polar loop linearization topology

The topology shown in fig. 3.2 is different from PLTx in the sense that the amplitude loop does not modulate the PA supply voltage or bias, but modulates the envelope of the PA input signal. The input is assumed to be an envelope and phase modulated IF signal. It is first split into two parts. Envelope of the first one is detected in order to obtain AM data and the second one is sent to a limiter to obtain just the phase modulated carrier. A portion of the PA output is taken using a coupler and it is down converted. This signal is also split into two parts. Again one part is envelope detected to obtain AM

data and the other is sent to a limiter to obtain the phase modulated carrier, both including PA nonlinearities. The two phase modulated signals from input and feedback are sent to frequency dividers and a PLL in order to force phase modulation to cancel the AM/PM nonlinearity of the PA. Also, the envelope detected input and feedback signals are sent to a differential amplifier to obtain an error signal cancelling the AM/AM nonlinearity. VCO and differential amplifier output signals are sent to a mixer in order to obtain amplitude and phase modulated PA input. In addition to there are various implementation possibilities. For example in some cases the required amount of linearization is low and it is sufficient to correct just AM/AM nonlinearities with envelope feedback.

Cartesian loop linearization:

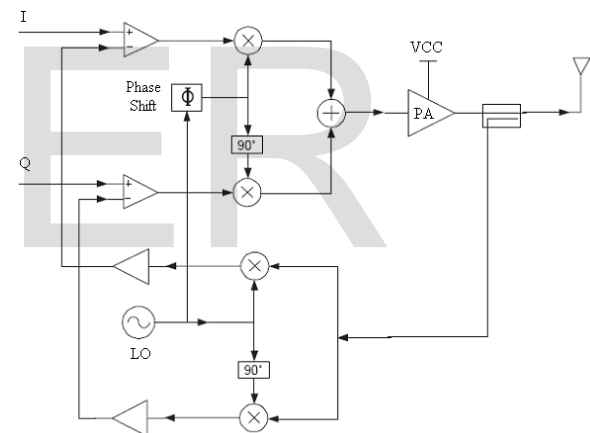

Figure 6: Cartesian loop linearization block diagram.

The problem of bandwidth widening in polar loop can be solved by Cartesian loop linearization technique. Fig. 3.3 shows a general block diagram. In Cartesian feedback I- and Q-signals are used to correct amplifier nonlinearities instead of R and θ as in polar loop. I and Q have similar spectral properties as RF signal whereas R and θ have much larger bandwidths [5]. In fig. 3.3 a demodulator is used in the feedback path in order to obtain distorted Cartesian modulation components from PA output. Demodulated and scaled I- and Q-signals are

subtracted from the input I- and Q-signals to obtain the PA input baseband signals resulting in linear operation. The circuit in fig. 3.3 is implemented in RF because IF Cartesian loop is undesirable due to the additional delay added to feedback loop.

Predistortion:

The idea behind predistortion is to expand the input signal prior a PA in such a way that the nonlinearities due to the PA are compensated. It is realized by implementing a nonlinear block in front of the nonlinear PA generating input signal level dependent distortion elements opposite of the distortion caused by the PA. As a result the cascade of these nonlinear blocks has a linear response.

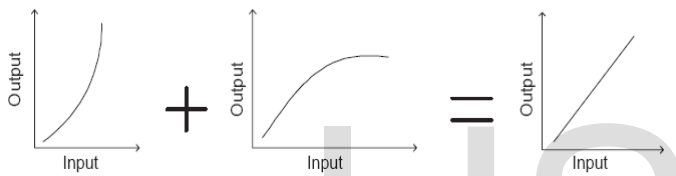

Figure 7: Basic steps of Predistortion

The figure shows AM/AM correction done by the predistorter. In general the similar correction is also done for phase (AM/PM) by adding a phase to the input signal opposite of the phase shift due to the PA. Predistortion can be realized in two different ways, analog or digital implementation. Analog predistortion is realized by creating the required AM/AM and AM/PM nonlinearities canceling the effects of PA using analog components.

It can be implemented at RF, IF or baseband. In the digital predistortion case however the system is realized with digital components and it is implemented usually at baseband. In predistortion systems first the PA characteristics must be obtained in order to calculate the required inverse nonlinearity compensating the PA nonlinearity. For a good system performance precise AM/AM and AM/PM characteristics are required. Although in some cases they can be assumed

not to depend on frequency (static case), actually they do.

Results and Discussion:

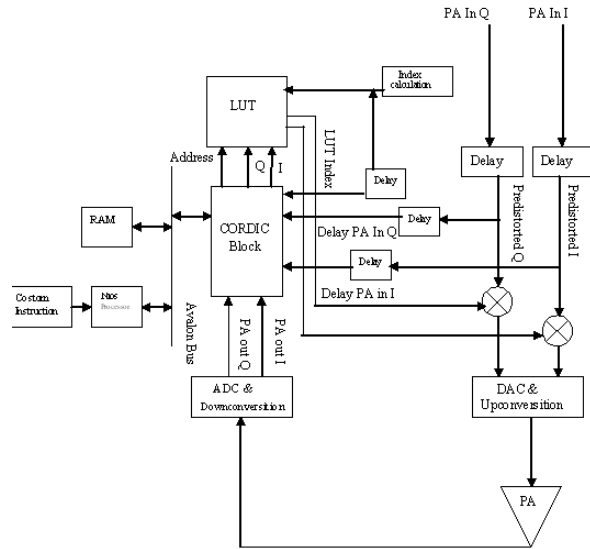

Fig 8: Proposed Digital Predistortion system

The predistorting function, F , is assumed to be a function of the magnitude of the input signal. The predistorting function is implemented using a complex multiplier, a Look-Up Table and an Address Generation block that selects the appropriate coefficient from the look-up table, given the magnitude of the input signal. The coefficients stored in the look-up table are the value of the predistortion function at certain input signal magnitudes. Thus, the predistortion function is not implemented in an analytic manner; rather, it is only calculated at a specified number of points.

For look-up table entries, the plots show the cumulative distribution of the entries over the range of the input signal magnitude for the magnitude and power distributions. Overlaid upon the distributions is the amplifier response, illustrating where the entries fall along the amplifier response. The last entry in both distributions falls at the maximum input power level that can be linearized (approximately 0.4 dBm). The look-up table entries are equally spaced over the range of the magnitude of the input signal in the case of magnitude indexing,

whereas, more look-up table entries are distributed at the higher end of the range in the case of power indexing.

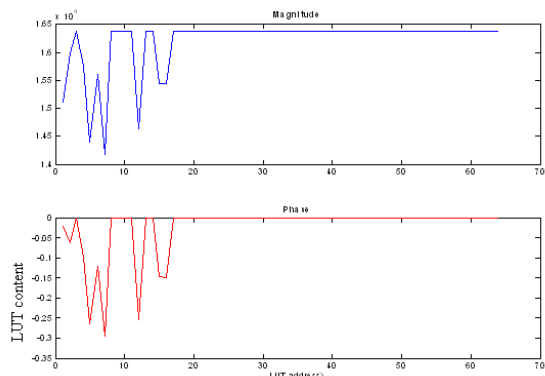

Figure 9: Magnitude and phase of the

1. Error Vector Magnitude:

EVM for non-predistortion system
 EVM for Predistortion system EVM
 = 102.6331%

2. Average Error Vector Magnitude:

Average EVM for non-predistortion system
 = 108.7263%,
 Average EVM for predistortion system EVM
 = 102.6331%
 EVM reduction over non_predistortion
 = 5.604%

3. Mean values over last 500 input samples: Non-Predistorted system:

Absolute Phase Error = 3421.21545
 Absolute Magnitude Error
 =1049.64671

4. Mean values over last 500 input samples: Predistorted system:

Absolute Phase Error
 =3077.30933
 Absolute Magnitude Error
 = 1007.00127

5. Predistorted reduction compared to non-predistortion:

Mean Absolute Phase Error reduction
 = 10.052%
 Mean Absolute Magnitude Error reduction
 = 4.063%

6. Predistortion: 3rd order:

Average sideband magnitude
 =-55.360dB,
 Max sideband magnitude
 =-28.364dB

7. Predistortion: 5th order:

Average sideband magnitude = -70.594dB,
 Max sideband magnitude = -47.468dB
No Predistortion 3rd order:
 Average sideband magnitude = -57.124dB,
 Max sideband magnitude = -32.873dB
No Predistortion: 5th order:
 Average sideband magnitude =-84.975dB,
 Max sideband magnitude = -55.535dB

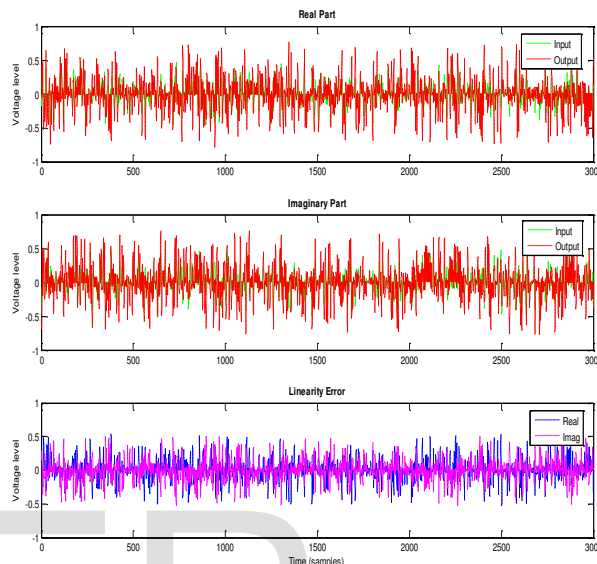

Fig 10: Normalized Linearity of Power amplifier

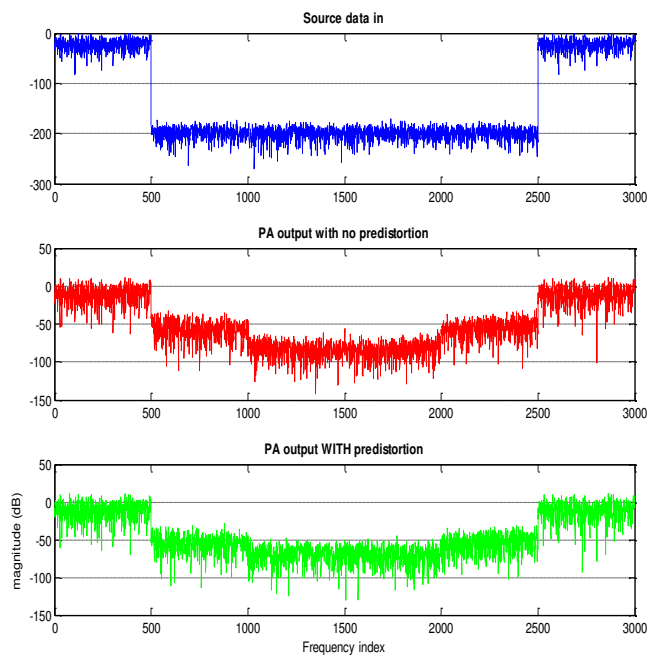

Figure 11:frequency plot for DPD system

Conclusion:

This paper considered the design of digital predistortion systems to linearize power amplifiers with memory effects. By adding a digital predistorter in the base band, the power amplifier is allowed to operate into its nonlinear region, thereby significantly increasing its efficiency. The efficiency gain translates into electricity and cooling cost savings for service providers and longer battery life for mobile terminal users. The challenge here is to address the memory effects exhibited by the higher power amplifiers or the power amplifiers for wideband signals. In addition, analog components in the transmitter have imperfections that need to be compensated as well.

References:

1. NavidLashkarian, Chris Dick FPGA implementation of digital predistortion linearizers for wideband power Amplifiers; Signal Processing Division, Xilinx Inc., San Jose, USA,.2007.
2. Lei Ding, Digital Predistortion of Power Amplifiers for Wireless Applications; 2004.
3. Cripps, S.C.: RF power 2005. Microwave Journal 48 (2005), 22-36.
4. Euns, C.; Powers, E.J.: A new Volterra predistorter based on the indirect learning architecture. IEEE Tran. On Signal Processing 45 (1997), 223-227.
5. Kim, J.; Konstantinou, K.: Digital predistortion of wideband signals based on power amplifier model with memory. Electronics Letters 37 (2001), 1417-1418.
6. NazimCeylan Linearization of power amplifiers by means of digital predistortion– Erlangen 2005.
7. García, P.; Ortega, A.; de Mingo, J.; Valdovinos, A.: Nonlinear distortion cancellation using LINC transmitters in OFDM systems. IEEE Trans. On Broadcasting 51 (2005), 84-93.
8. Altera , Digital Predistortion Reference Design, Altera corporation, 2006
9. Shawn P. Stapleton, Agilent EEs of EDA Digital Predistortion of Power Amplifiers in cooperation with: Agilent Technologies, Inc, 2005.
10. Ding, L.; Raich, R.; Zhou, G.T.: A Hammerstein predistortion linearization design based on the indirect learning. IEEE Int. Conf. on Acoustics, Speech, Signal Proc. 3 (2002), 2689-2692.
11. Jung, W.J.; Kim, W.R.; Kim, K.M.; Lee, K.B.: Digital predistorter using multiple lookup tables. IEEE Electronics Letters 39 (2003), 1386-1388.
12. Baudoin, G.; Jardin, P.: Adaptive polynomial pre-distortion for linearization of power amplifiers in wireless communications and WLAN. Int. Conf. on Trends in Comm. EUROCON 2001 1, 157-160.
13. Marsalek, R.; Jardin, P.; Baudoin, G.: From post-distortion to pre-distortion for power amplifiers linearization. IEEE Electronics Letters 7 (2003), 308-310.
14. Ma, Z., Zierdt, M., Dunkleberger, L., and Pastalan, J., “Memoryless power Amplifier characterization for digital baseband predistortion (ii).” unpublished work, Jan. 2001.